

NMRA STANDARD	
Scale Wheels	
Apr 3, 2026	S-4.2 Draft

1 General

This Standard is to provide target dimensions for scale wheels and an upper and lower limit whereby wheels within these limits will operate without fault on track built within the limits of S-3.2.

1.2 Introduction and Intended Use (Informative)

It is not the specific purpose of the NMRA STANDARDS to set production dimensions or tolerances but rather to set limits which manufacturers can use when setting their tolerances. When used to determine manufacturing tolerances, care must be taken to ensure that the production dimensions are not at the extreme edge of the range specified. Specific NMRA Tech Notes supplement the standards to provide additional guidance.

1.3 References

This standard should be interpreted in the context of the following NMRA Standards, Technical Notes, and Technical Information.

1.3.2 Normative

- S-1 General Overview
- S-1.2 General Standard Scales
- S-4 Wheels
- S-4.1 Wheels – Proto Scales
- S-4.3 Wheels with Deep Flanges
- S-3.2 Trackwork – Standard Scales
- RP-25 Wheel Contour

1.3.3 Informative

- TN-4.2 Wheels Standard Scale (Yet to be written,)

1.4 Terminology

Term	Definition
Wheel set	Two wheels mounted on an axle.
Column Headings	
Check Gauge – K	The distance between the back of one wheel to the outside face of the flange on the opposite wheel.
Back-To-Back – B	The distance between the back of one wheel to the back of the opposite wheel.
Wheel Width – N	The distance from the back of a wheel to the face of the same wheel.
Flange Depth – D	The distance from the root of the wheel flange at the tread to the farthest point of the flange.
Flange Width – T	The distance from the inside face of the flange to the outside face of the flange.

Term	Definition
Tread Width – W	The width of the tread of the wheel. Total wheel width (N) minus the flange width (T). The tread width (W) measured from the outside edge of the wheel to the root of the flange (does not include the width of the flange).
Wheel Width (Code)	<p>The width of the wheel (N) measured from the back of a wheel to the face of the same wheel.</p> <p>Value is expressed in fractions of an inch for very large scales, and in thousandths of an inch for all other scales. For example, Code 110 refers to a wheel width of 0.110 inches wide. Code 72 refers to a wheel width of 0.072 inches wide.</p>

2 Data Tables

2.1 1" Scale (Ratio 1:12)

2.1.1 Standard Scale: Imperial Data Governs

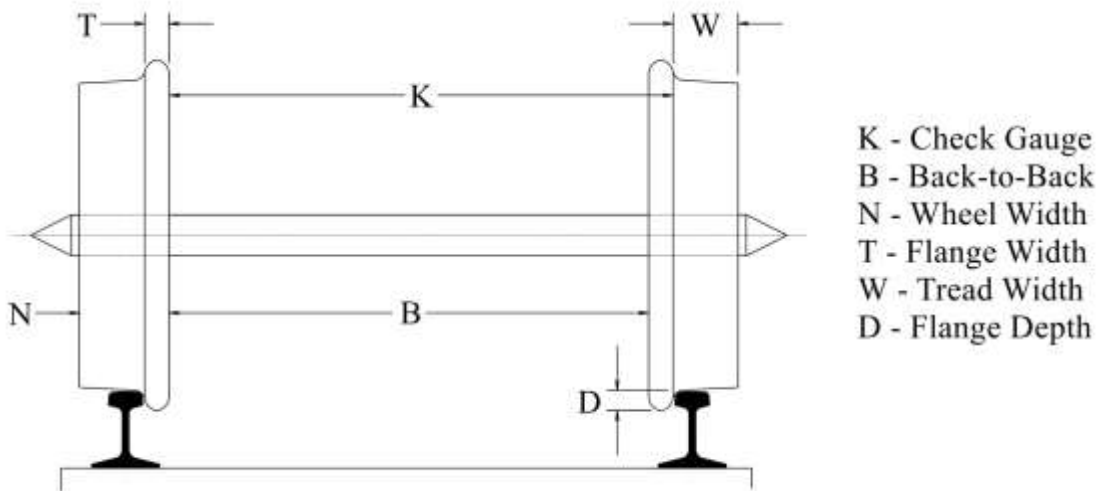

K			B*			N	D	T	Wheel Width
Check Gauge			Back-to-Back			Wheel Width	Flange Depth	Flange Width	
Min	Tgt	Max	Min	Tgt	Max	Nom	Tgt	Tgt	Code
Imperial (Inch)									
4.563	4.579	4.581	4.438	4.454	4.456	0.505	0.156	0.125	500
Metric (mm)									
115.90	116.31	116.36	112.73	113.13	113.18	12.83	3.96	3.18	500

Notes:

- * 1 The Back-to-Back, B, is derived from the equation $B=K-T$. K is the primary controlling dimension. Adjust B as needed to meet the K dimension.
- 2 See **RP-25, Wheel Contour**, for recommended wheel contour.
- 3 To avoid difficulty with long wheelbase locomotives in curves sharper than 20 degrees or where guardrails are used on both sides as in special trackwork, see **RP-7, Track Centers and Obstacle Clearances**. Additionally:
- Allow lateral movement in driver axles of 1 percent of the rigid wheelbase length;
 - Remove flanges from center drivers.

2.2 3/4" Scale (Ratio 1:16)

2.2.1 Standard Scale: Imperial Data Governs

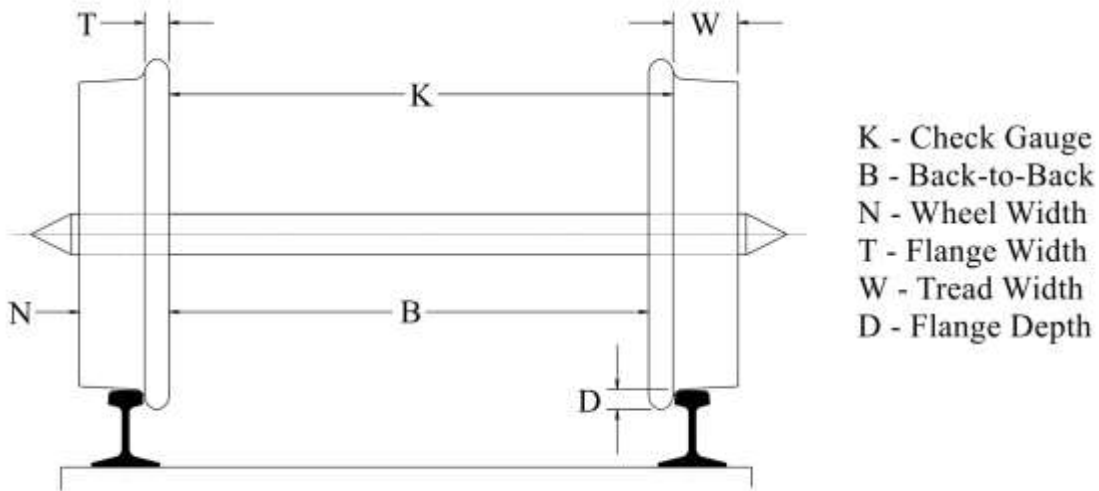

K			B*			N	D	T	Wheel Width
Check Gauge			Back-to-Back			Wheel Width	Flange Depth	Flange Width	
Min	Tgt	Max	Min	Tgt	Max	Nom	Tgt	Tgt	Code
Imperial (Inch)									
3.313	3.347	3.349	3.219	3.253	3.255	0.410	0.125	0.094	406
Metric (mm)									
84.15	85.01	85.06	81.76	82.63	82.68	10.41	3.18	2.39	406

Notes:

- * 1 The Back-to-Back, B, is derived from the equation $B=K-T$. K is the primary controlling dimension. Adjust B as needed to meet the K dimension.
- 2 See **RP-25, Wheel Contour**, for recommended wheel contour.
- 3 To avoid difficulty with long wheelbase locomotives in curves sharper than 20 degrees or where guardrails are used on both sides as in special trackwork, see **RP-7, Track Centers and Obstacle Clearances**. Additionally:
- Allow lateral movement in driver axles of 1 percent of the rigid wheelbase length;
 - Remove flanges from center drivers.

2.3 F Scale (Ratio 1:20.3)

2.3.1 Standard Scale: Imperial Data Governs

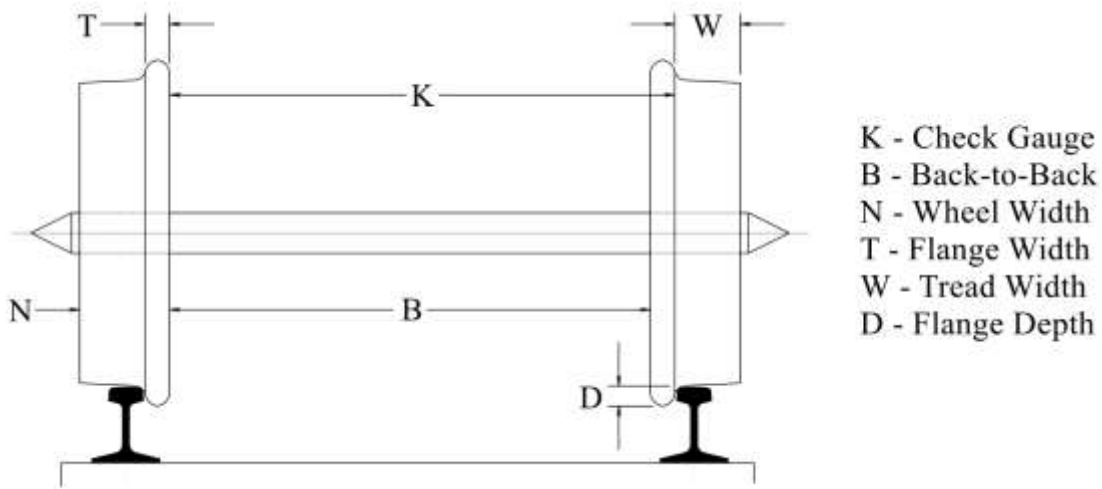

K			B*			N	D	T	Wheel Width
Check Gauge			Back-to-Back			Wheel Width	Flange Depth	Flange Width	
Min	Tgt	Max	Min	Tgt	Max	Nom	Tgt	Tgt	Code
F Standard Gauge									
Imperial (Inch)									
2.660	2.676	2.680	2.597	2.613	2.617	0.284	0.090	0.063	284
Metric (mm)									
67.56	67.97	68.07	65.96	66.37	66.47	7.21	2.29	1.60	284
Fn3 (36") Narrow Gauge									
Imperial (Inch)									
1.619	1.633	1.648	1.560	1.575	1.594	0.250	0.066	0.059	250
Metric (mm)									
41.12	41.48	41.86	39.62	40.01	40.49	6.35	1.68	1.50	250

Notes:

- * 1 The Back-to-Back, B, is derived from the equation $B=K-T$. K is the primary controlling dimension. Adjust B as needed to meet the K dimension.
- 2 See **RP-25, Wheel Contour**, for recommended wheel contour.
- 3 To avoid difficulty with long wheelbase locomotives in curves sharper than 20 degrees or where guardrails are used on both sides as in special trackwork, see **RP-7, Track Centers and Obstacle Clearances**. Additionally:
- Allow lateral movement in driver axles of 1 percent of the rigid wheelbase length;
 - Remove flanges from center drivers.

2.4 Large Scale (Ratio Varies)

2.4.1 Standard Scale: Imperial Data Governs

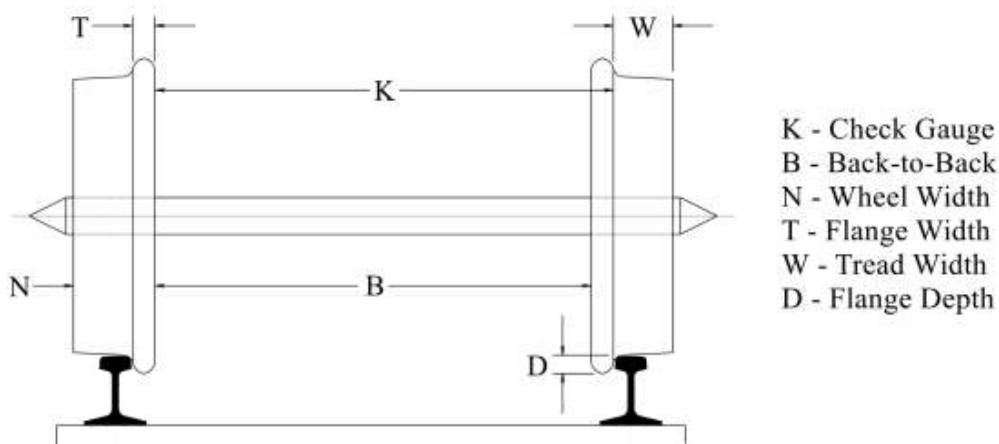

K - Check Gauge
B - Back-to-Back
N - Wheel Width
T - Flange Width
W - Tread Width
D - Flange Depth

K			B*			N		D	T		
Check Gauge			Back-to-Back			Wheel Width		Flange Depth	Flange Width		
Min	Tgt	Max	Min	Tgt	Max	Min	Max	Max	Min	Tgt	Max
Imperial (Inch)											
1.619	1.633	1.648	1.570	1.575	1.594	0.236	0.271	0.066	0.041	0.059	0.061
Metric (mm)											
41.12	41.48	41.86	39.88	40.01	40.49	5.99	6.88	1.68	1.04	1.50	1.55

Notes:

- * 1 The Back-to-Back, B, is derived from the equation $B=K-T$. K is the primary controlling dimension. Adjust B as needed to meet the K dimension.
- 2 A wheel tread taper of 3 degrees is recommended for all wheels.
- 3 "Large Scales" standards cover all common commercial scales running on LS 45mm gauge track (1:32, 1:29, 1:22.5, 1:20.3) without regard as to whether the trains are standard or narrow gauge.
- 4 Due to the inherent nature of large scale trains, the wheel and track standards for "Standard" (Sx.2) and "Deep Flange" (Sx.3) are identical except in terms of flange width and depth.
- 5 Developing a single wheel profile for all of large scale is not recommended nor needed due to the fact that there are multiple scales running on the same LS 45mm gauge track. Each scale has developed its own scale-specific profile, all of which conform to LS 45mm gauge standard.
- 6 While there is a stated "target" wheel width, manufacturers should take into consideration the scale of their models in determining where in that spectrum their wheels would best fall. For instance, .271" scales out to the proper width for a 5.5" wheel in 1:20.3, but would be oversized for a 1:32 model, for which .236" is more
- 7 With regard to 1:20.3 (also designated "F" scale), trains built to that scale running on LS 45mm gauge track are also classified Fn3. Standards for Fn3 wheels are identical to those for LS, with exception the wheels are given more specific targets for tread width and flange depth. Track standards for Fn3 are to be identical to those used for LS 45mm gauge.
- 8 The standards do not specify a fillet between the tread and flange, but common practice has proven such to be beneficial to the performance of the wheel. A fillet radius between .020" and .030" depending on the proportional width of the tire is highly recommended.
- 9 A wheel tread taper of 3 degrees is recommended for all wheels.
- 10 It is traditionally viewed in the large scale community that the back-to-back spacing on the wheels is a primary dimension. Should a manufacturer or modeler opt to use flanges greater than 0.076", the back-to-back spacing should be narrowed from the published Target Value to compensate and still fall within Check-gauge tolerances for the wheels.

40 **2.5 O Scale (Ratio 1:48)**

2.5.1 Standard Scale: Imperial Data Governs

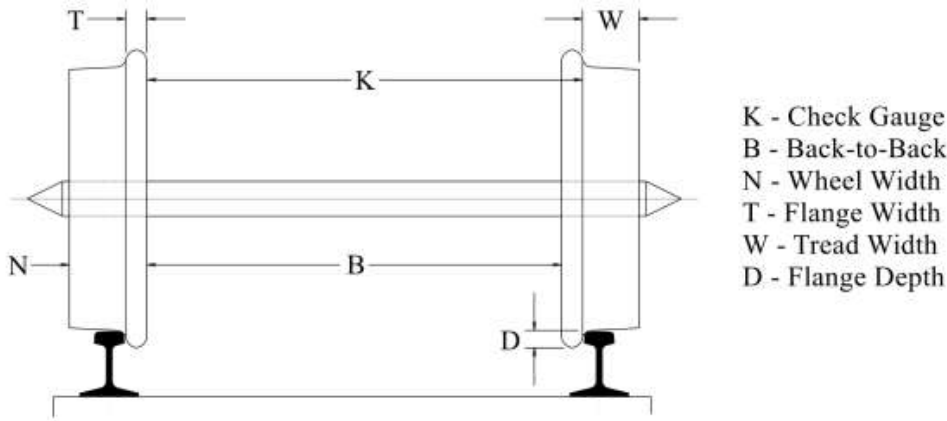

K - Check Gauge
 B - Back-to-Back
 N - Wheel Width
 T - Flange Width
 W - Tread Width
 D - Flange Depth

K			B*			N	D	T	
Check Gauge			Back-to-Back			Wheel Width	Flange Depth	Flange Width	Wheel Width
Min	Tgt	Max	Min	Tgt	Max	Nom	Tgt	Tgt	Code
O Standard Gauge									
Imperial (Inch)									
1.171	1.177	1.179	1.132	1.138	1.140	0.145	0.036	0.039	145
Metric (mm)									
29.74	29.90	29.95	28.75	28.91	28.96	3.68	0.91	0.99	145
On3 (36") Narrow Gauge									
Imperial (Inch)									
0.697	0.703	0.705	0.666	0.672	0.674	0.116	0.030	0.031	116
Metric (mm)									
17.70	17.86	17.91	16.92	17.07	17.12	2.95	0.76	0.79	116
On30 (30") Narrow Gauge									
Imperial (Inch)									
0.596	0.603	0.605	0.566	0.573	0.575	0.110	0.028	0.030	110
Metric (mm)									
15.14	15.32	15.37	14.38	14.55	14.61	2.79	0.71	0.76	110
On2 (24") Narrow Gauge									
Imperial (Inch)									
0.446	0.453	0.455	0.416	0.423	0.425	0.110	0.028	0.030	110
Metric (mm)									
11.33	11.51	11.56	10.57	10.74	10.80	2.79	0.71	0.76	110

Notes:

* 1 The Back-to-Back, B, is derived from the equation $B=K-T$. K is the primary controlling dimension. Adjust B as needed to meet the K dimension.

2 See **RP-25, Wheel Contour**, for recommended wheel contour.

3 To avoid difficulty with long wheelbase locomotives in curves sharper than 20 degrees or where guardrails are used on both sides as in special trackwork, see **RP-7, Track Centers and Obstacle Clearances**. Additionally:

- Allow lateral movement in driver axles of 1 percent of the rigid wheelbase length;
- Remove flanges from center drivers.

2.6 S Scale (Ratio 1:64)

2.6.1 Standard Scale: Imperial Data Governs

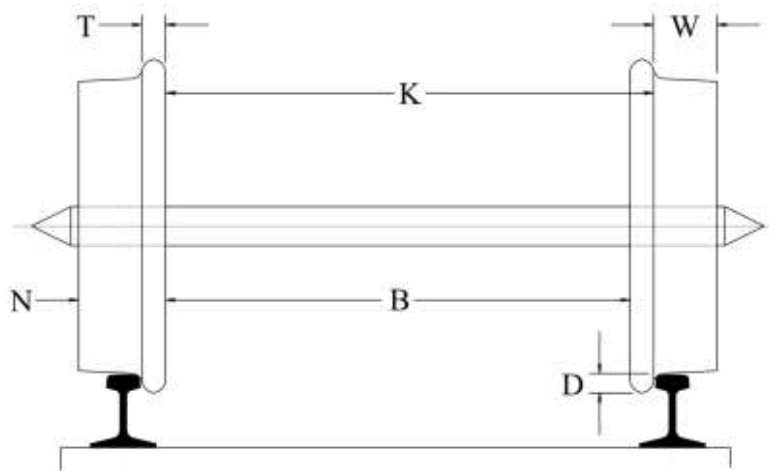

K - Check Gauge
 B - Back-to-Back
 N - Wheel Width
 T - Flange Width
 W - Tread Width
 D - Flange Depth

K			B*			N	D	T	
Check Gauge			Back-to-Back			Wheel Width	Flange Depth	Flange Width	Wheel Width
Min	Tgt	Max	Min	Tgt	Max	Nom	Tgt	Tgt	Code
S Standard Gauge									
Imperial (Inch)									
0.830	0.837	0.839	0.800	0.807	0.809	0.110	0.030	0.030	110
Metric (mm)									
21.08	21.26	21.31	20.32	20.50	20.55	2.79	0.76	0.76	110
Sn3 (36") Narrow Gauge									
Imperial (Inch)									
0.510	0.517	0.519	0.480	0.487	0.489	0.110	0.030	0.030	110
Metric (mm)									
12.95	13.13	13.18	12.19	12.37	12.42	2.79	0.76	0.76	110
Sn2 (24") Narrow Gauge									
Imperial (Inch)									
0.370	0.375	0.377	0.345	0.350	0.352	0.088	0.023	0.025	88
Metric (mm)									
9.40	9.53	9.58	8.76	8.89	8.94	2.24	0.58	0.64	88
Notes:									
* 1 The Back-to-Back, B, is derived from the equation $B=K-T$. K is the primary controlling dimension. Adjust B as needed to meet the K dimension.									
2 See RP-25, Wheel Contour , for recommended wheel contour.									
3 To avoid difficulty with long wheelbase locomotives in curves sharper than 20 degrees or where guardrails are used on both sides as in special trackwork, see RP-7, Track Centers and Obstacle Clearances . Additionally:									
<ul style="list-style-type: none"> • Allow lateral movement in driver axles of 1 percent of the rigid wheelbase length; • Remove flanges from center drivers. 									

2.7 OO Scale (Ratio 1:76.2)

2.7.1 Standard Scale: Imperial Data Governs

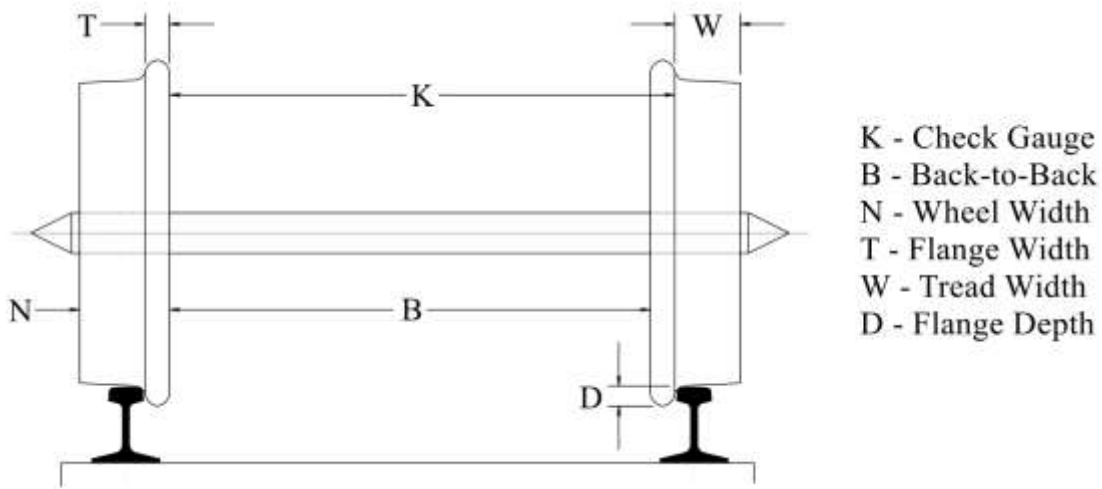

K - Check Gauge
 B - Back-to-Back
 N - Wheel Width
 T - Flange Width
 W - Tread Width
 D - Flange Depth

K			B*			N	D	T	Wheel Width
Check Gauge			Back-to-Back			Wheel Width	Flange Depth	Flange Width	
Min	Tgt	Max	Min	Tgt	Max	Nom	Tgt	Tgt	Code
Imperial (Inch)									
0.696	0.703	0.705	0.666	0.673	0.675	0.110	0.028	0.030	110
Metric (mm)									
17.68	17.86	17.91	16.92	17.09	17.15	2.79	0.71	0.76	110

Notes:

- * 1 The Back-to-Back, B, is derived from the equation $B=K-T$. K is the primary controlling dimension. Adjust B as needed to meet the K dimension.
- 2 See **RP-25, Wheel Contour**, for recommended wheel contour.
- 3 To avoid difficulty with long wheelbase locomotives in curves sharper than 20 degrees or where guardrails are used on both sides as in special trackwork, see **RP-7, Track Centers and Obstacle Clearances**. Additionally:
- Allow lateral movement in driver axles of 1 percent of the rigid wheelbase length;
 - Remove flanges from center drivers.

50 **2.8 HO Scale (Ratio 1:87.1)**

2.8.1 Standard Scale: Imperial Data Governs

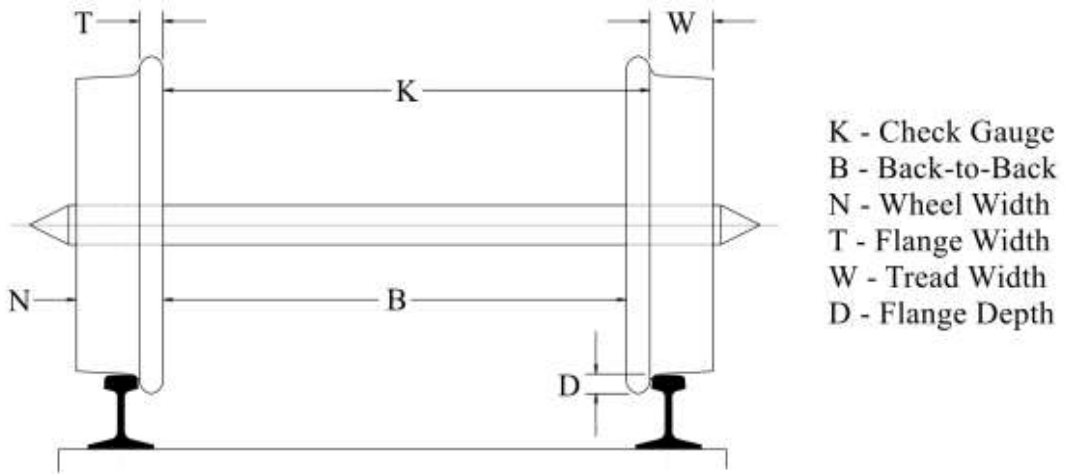

K - Check Gauge
 B - Back-to-Back
 N - Wheel Width
 T - Flange Width
 W - Tread Width
 D - Flange Depth

K			B*			N	D	T	Wheel Width
Check Gauge			Back-to-Back			Wheel Width	Flange Depth	Flange Width	
Min	Tgt	Max	Min	Tgt	Max	Nom	Tgt	Tgt	Code
HO Standard Gauge									
Imperial (Inch)									
0.596	0.603	0.605	0.566	0.573	0.575	0.110	0.028	0.030	110
Metric (mm)									
15.14	15.32	15.37	14.38	14.55	14.61	2.79	0.71	0.76	110
HOn3 (36") Narrow Gauge									
Imperial (Inch)									
0.370	0.375	0.377	0.345	0.350	0.352	0.088	0.023	0.025	88
Metric (mm)									
9.40	9.53	9.58	8.76	8.89	8.94	2.24	0.58	0.64	88
HOn2 (24") Narrow Gauge									
Imperial (Inch)									
0.240	0.244	0.246	0.220	0.224	0.226	0.072	0.023	0.020	72
Metric (mm)									
6.10	6.20	6.25	5.59	5.69	5.74	1.83	0.58	0.51	72
Notes:									
* 1 The Back-to-Back, B, is derived from the equation $B=K-T$. K is the primary controlling dimension. Adjust B as needed to meet the K dimension. 2 See RP-25, Wheel Contour , for recommended wheel contour. 3 To avoid difficulty wth long wheelbase locomotives in curves sharper than 20 degrees or where guardrails are used on both sides as in special trackwork, see RP-7, Track Centers and Obstacle Clearances . Additionally: <ul style="list-style-type: none"> • Allow lateral movement in driver axles of 1 percent of the rigid wheelbase length; • Remove flanges from center drivers. 									

2.9 TT Scale (Ratio 1:120)

2.9.1 Standard Scale: Imperial Data Governs

NOTE: *Italicized values indicate changes from last published standard*

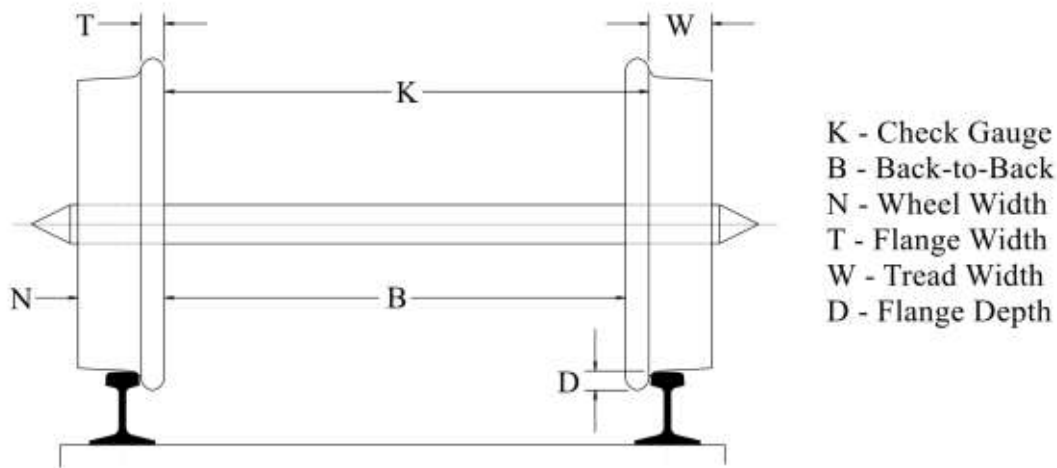

K - Check Gauge
 B - Back-to-Back
 N - Wheel Width
 T - Flange Width
 W - Tread Width
 D - Flange Depth

K			B*			N	D	T	
Check Gauge			Back-to-Back			Wheel Width	Flange Depth	Flange Width	Wheel Width
Min	Tgt	Max	Min	Tgt	Max	Nom	Tgt	Tgt	Code
TT Standard Gauge									
Imperial (Inch)									
0.427	0.435	0.437	0.407	0.415	0.417	0.079	0.022	0.020	79
Metric (mm)									
10.85	11.05	11.10	10.34	10.54	10.59	2.01	0.56	0.51	79
TTn42 (42") Narrow Gauge									
Imperial (Inch)									
0.317	0.321	0.323	0.297	0.301	0.303	0.072	0.026	0.020	72
Metric (mm)									
8.05	8.15	8.20	7.54	7.65	7.70	1.83	0.66	0.51	72
TTn3 (36") Narrow Gauge									
Imperial (Inch)									
0.265	0.268	0.270	0.245	0.248	0.250	0.072	0.022	0.020	72
Metric (mm)									
6.73	6.81	6.86	6.22	6.30	6.35	1.83	0.56	0.51	72
Notes:									
* 1 The Back-to-Back, B, is derived from the equation $B=K-T$. K is the primary controlling dimension. Adjust B as needed to meet the K dimension.									
2 See RP-25, Wheel Contour , for recommended wheel contour.									
3 To avoid difficulty with long wheelbase locomotives in curves sharper than 20 degrees or where guardrails are used on both sides as in special trackwork, see RP-7, Track Centers and Obstacle Clearances . Additionally:									
<ul style="list-style-type: none"> • Allow lateral movement in driver axles of 1 percent of the rigid wheelbase length; • Remove flanges from center drivers. 									

2.10 N Scale (Ratio 1:160)

2.10.1 Standard Scale: Imperial Data Governs

NOTE: *Italicized values indicate changes from last published standard*

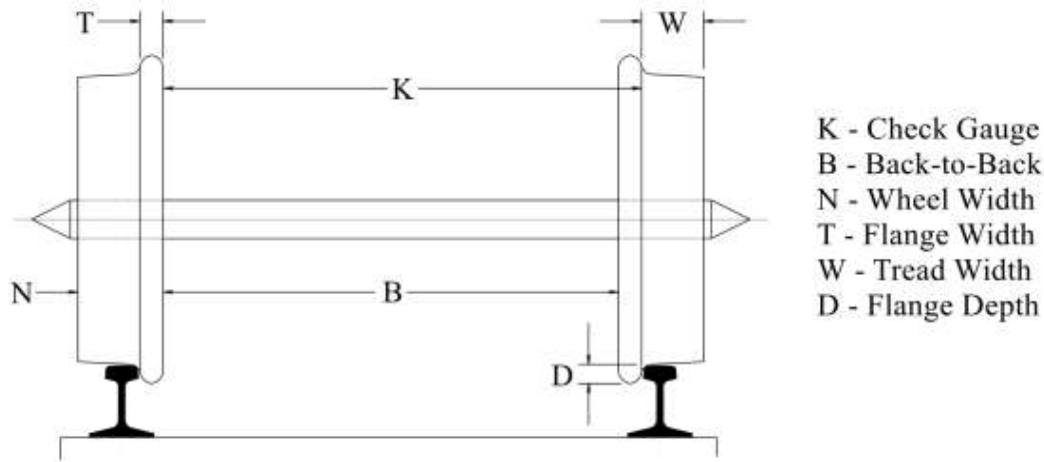

K			B*			N	D	T	
Check Gauge			Back-to-Back			Wheel Width	Flange Depth	Flange Width	Wheel Width
Min	Tgt	Max	Min	Tgt	Max	Nom	Tgt	Tgt	Code
N Standard Gauge									
Imperial (Inch)									
0.317	0.321	0.323	0.297	0.301	0.303	0.072	0.022	0.020	72
Metric (mm)									
8.05	8.15	8.20	7.54	7.65	7.70	1.83	0.56	0.51	72
Nn3 (36") Narrow Gauge									
Imperial (Inch)									
<i>0.225</i>	<i>0.227</i>	<i>0.229</i>	<i>0.211</i>	<i>0.213</i>	<i>0.215</i>	0.054	0.020	0.014	54
Metric (mm)									
<i>5.72</i>	<i>5.77</i>	<i>5.82</i>	<i>5.36</i>	<i>5.41</i>	<i>5.46</i>	1.37	0.51	0.36	54
Nn2 (24") Narrow Gauge									
Imperial (Inch)									
<i>0.145</i>	<i>0.147</i>	<i>0.149</i>	<i>0.131</i>	<i>0.133</i>	<i>0.135</i>	0.054	0.020	0.014	54
Metric (mm)									
<i>3.68</i>	<i>3.73</i>	<i>3.78</i>	<i>3.33</i>	<i>3.38</i>	<i>3.43</i>	1.37	0.51	0.36	54
Notes:									
* 1 The Back-to-Back, B, is derived from the equation $B=K-T$. K is the primary controlling dimension. Adjust B as needed to meet the K dimension. 2 See RP-25, Wheel Contour , for recommended wheel contour. 3 To avoid difficulty with long wheelbase locomotives in curves sharper than 20 degrees or where guardrails are used on both sides as in special trackwork, see RP-7, Track Centers and Obstacle Clearances . Additionally: <ul style="list-style-type: none"> • Allow lateral movement in driver axles of 1 percent of the rigid wheelbase length; • Remove flanges from center drivers. 									

2.11 Z Scale (Ratio 1:220)

2.11.1 Standard Scale: Imperial Data Governs

NOTE: *Italicized values indicate changes from last published standard*

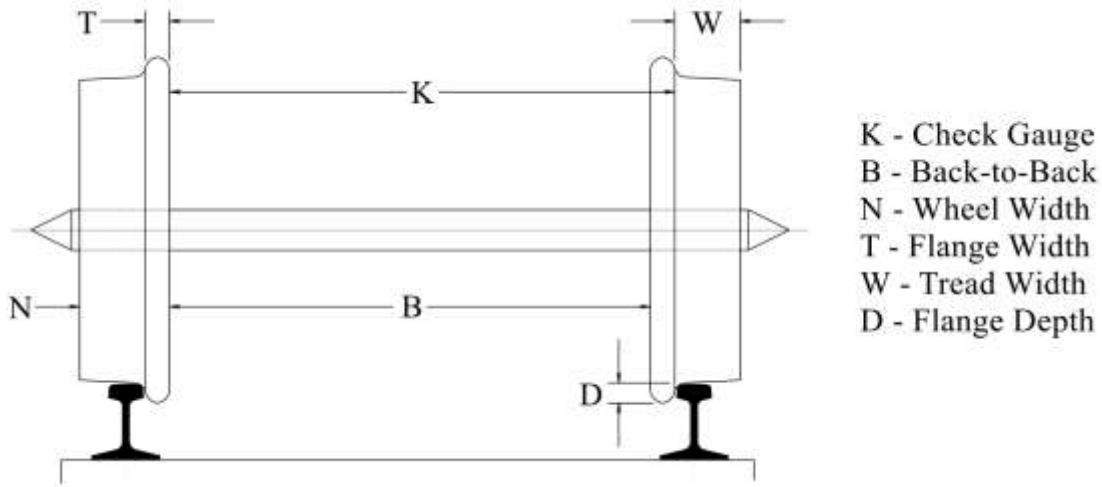

K - Check Gauge
 B - Back-to-Back
 N - Wheel Width
 T - Flange Width
 W - Tread Width
 D - Flange Depth

K			B*			N	D	T	Wheel Width
Check Gauge			Back-to-Back			Wheel Width	Flange Depth	Flange Width	
Min	Tgt	Max	Min	Tgt	Max	Nom	Tgt	Tgt	Code
Imperial (Inch)									
<i>0.235</i>	<i>0.237</i>	<i>0.239</i>	<i>0.221</i>	<i>0.223</i>	<i>0.225</i>	0.054	0.020	0.014	54
Metric (mm)									
<i>5.97</i>	<i>6.02</i>	<i>6.07</i>	<i>5.61</i>	<i>5.66</i>	<i>5.72</i>	1.37	0.51	0.36	54

Notes:

- * 1 The Back-to-Back, B, is derived from the equation $B=K-T$. K is the primary controlling dimension. Adjust B as needed to meet the K dimension.
- 2 See **RP-25, Wheel Contour**, for recommended wheel contour.
- 3 To avoid difficulty with long wheelbase locomotives in curves sharper than 20 degrees or where guardrails are used on both sides as in special trackwork, see **RP-7, Track Centers and Obstacle Clearances**. Additionally:
- Allow lateral movement in driver axles of 1 percent of the rigid wheelbase length;
 - Remove flanges from center drivers.

3 Document History

Date	Description
Jan 2019	Previous release provided a target rather than limits. Several previous releases of unknown dates. The first Standard was adopted in 1936.
3-Apr-2026	Revision to migrate to new template. Each scale on an individual page. Provided maximum and minimum dimensions rather than previous plus and minus to avoid errors where they may be calculated mentally. There were changes to back to back (B) and therefore also check gauge (K) to TTn3, Nn3, Nn2 and Z scales because of an interference between B and Span in turnouts if B was at the minimum and S was at the maximum. No changes to other dimensions were made.

Important Notices and Disclaimers Concerning NMRA Standards Documents

The Standards (S), Recommended Practices (RP), Technical Note (TN), and Technical Information (TI) documents of the National Model Railroad Association ("NMRA Standards documents") are made available for use subject to important notices and legal disclaimers. These notices and disclaimers, or a reference to this page, appear in all standards and may be found under the heading "Important Notices and Disclaimers Concerning NMRA Standards Documents."

Notice and Disclaimer of Liability Concerning the Use of NMRA Standards Documents

NMRA Standards documents are developed within the Standards and Conformance Department of the NMRA in association with certain Working Groups, members, and representatives of manufacturers and sellers. NMRA develops its standards through a consensus development process, which brings together volunteers representing varied viewpoints and interests to achieve the final product. NMRA Standards documents are developed by volunteers with modeling, railroading, engineering, and industry-based expertise. Volunteers are not necessarily members of NMRA, and participate without compensation from NMRA.

NMRA does not warrant or represent the accuracy or completeness of the material contained in NMRA Standards documents, and expressly disclaims all warranties (express, implied and statutory) not included in this or any other document relating to the standard or recommended practice, including, but not limited to, the warranties of: merchantability; fitness for a particular purpose; non-infringement; and quality, accuracy, effectiveness, currency, or completeness of material. In addition, NMRA disclaims any and all conditions relating to results and workmanlike effort. In addition, NMRA does not warrant or represent that the use of the material contained in NMRA Standards documents is free from patent infringement. NMRA Standards documents are supplied "AS IS" and "WITH ALL FAULTS."

Use of NMRA Standards documents is wholly voluntary. The existence of an NMRA Standard or Recommended Practice does not imply that there are no other ways to produce, test, measure, purchase, market, or provide other goods and services related to the scope of the NMRA Standards documents. Furthermore, the viewpoint expressed at the time that NMRA approves or issues a Standard or Recommended Practice is subject to change brought about through developments in the state of the art and comments received from users of NMRA Standards documents.

In publishing and making its standards available, NMRA is not suggesting or rendering professional or other services for, or on behalf of, any person or entity, nor is NMRA undertaking to perform any duty owed by any other person or entity to another. Any person utilizing any NMRA Standards document, should rely upon their own independent judgment in the exercise of reasonable care in any given circumstances or, as appropriate, seek the advice of a competent professional in determining the appropriateness of a given NMRA Standards document.

IN NO EVENT SHALL NMRA BE LIABLE FOR ANY DIRECT, INDIRECT, INCIDENTAL, SPECIAL, EXEMPLARY, OR CONSEQUENTIAL DAMAGES (INCLUDING, BUT NOT LIMITED TO: THE NEED TO PROCURE SUBSTITUTE GOODS OR SERVICES; LOSS OF USE, DATA, OR PROFITS; OR BUSINESS INTERRUPTION) HOWEVER CAUSED AND ON ANY THEORY OF LIABILITY, WHETHER IN CONTRACT, STRICT LIABILITY, OR TORT (INCLUDING NEGLIGENCE OR OTHERWISE) ARISING IN ANY WAY OUT OF THE PUBLICATION, USE OF, OR RELIANCE UPON ANY STANDARD OR RECOMMENDED PRACTICE, EVEN IF ADVISED OF THE POSSIBILITY OF SUCH DAMAGE AND REGARDLESS OF WHETHER SUCH DAMAGE WAS FORESEEABLE.

Translations

NMRA's development of NMRA Standards documents involves the review of documents in English only. In the event that an NMRA Standards document is translated, only the English version published by NMRA is the approved NMRA Standards document.

Official Statements

A statement, written or oral, that is not processed in accordance with NMRA policies for distribution of NMRA communications, or approved by the Board of Directors, an officer or committee chairperson, shall not be considered or inferred to be the official position of NMRA or any of its committees and shall not be considered to be, nor be relied upon as, a formal position of NMRA.

Comments on Standards

Comments for revision of NMRA Standards documents are welcome from any interested party, regardless of membership. However, **NMRA does not provide interpretations, consulting information, or advice pertaining to NMRA Standards documents.**

Suggestions for changes in documents should be in the form of a proposed change of text, together with appropriate supporting comments. Since NMRA standards represent a consensus of concerned interests, it is important that any responses to comments and questions also receive the concurrence of a balance of interests. For this reason, NMRA, its departments, Working Groups or committees cannot provide an instant response to comments, or questions except in those cases where the matter has previously been addressed. For the same reason, NMRA does not respond to interpretation requests. Any person who would like to participate in evaluating comments or in revisions to NMRA Standards documents may request participation in the relevant NMRA working group.

Laws & Regulations

Users of NMRA Standards documents should consult all applicable laws and regulations. Compliance with the provisions of any NMRA Standards document does not constitute compliance to any applicable regulatory requirements. Implementers of the standard are responsible for observing or referring to the applicable regulatory requirements. NMRA does not, by the publication of NMRA Standards documents, intend to urge action that is not in compliance with applicable laws, and NMRA Standards documents may not be construed as doing so.

Copyrights

NMRA Standards documents are copyrighted by NMRA under US and international copyright laws. They are made available by NMRA and are adopted for a wide variety of both public and private uses. These include both use, by reference, in laws and regulations, and use in private self-regulation, standardization, and the promotion of modeling, structural and engineering practices and methods. By making NMRA Standards documents available for use and adoption by public authorities and private users, NMRA does not waive any rights in copyright to the NMRA Standards documents.

IMPORTANT NOTICE

NMRA Standards documents do not guarantee or ensure safety, security, health, or environmental protection, or ensure against interference with or from other systems, devices or networks. NMRA Standards documents development activities consider research and information presented to the standards development group in developing any safety recommendations. Other information about safety practices, changes in technology or technology implementation, or impact by peripheral systems also may be pertinent to safety considerations during implementation of the standard. Implementers and users of NMRA Standards documents are responsible for determining and complying with all appropriate safety, security, environmental, health, and interference protection practices and all applicable laws and regulations.